

Installation Instructions

FOR HOLLOW METAL DOORS

1 - Trim the automatic door bottom from the lock side. The lock-side is the on the opposite end of the brass hex nut. Cut the piece to $\frac{3}{16}$ " (4.8mm) shorter than the entire width of the door.

2 - Drill a $\frac{7}{16}$ " (11.1 mm) hole at the bottom of the door on the hinge side. This will enable the adjusting brass hex nut to extend and press into the jamb. Use the diagram on the right as a guide.

3 - The adjusting brass nut should be extended through the hole ($\frac{1}{8}$ ") when installing the door bottom.

4 - Open and close the door while adjusting the brass nut to get the desired seal with the floor or sill. The maximum Drop is $\frac{1}{2}$ " (12.7mm) and adjustments are made after the automatic door bottom is fully installed. To adjust, turn the adjusting brass nut in or out. Do not over adjust to ensure proper functionality.

#7553

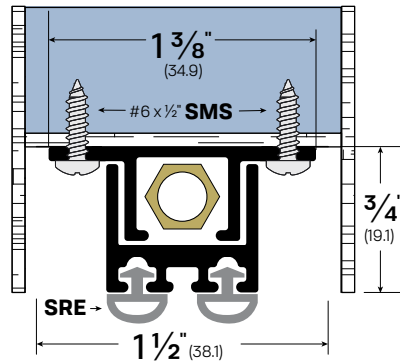

#71553

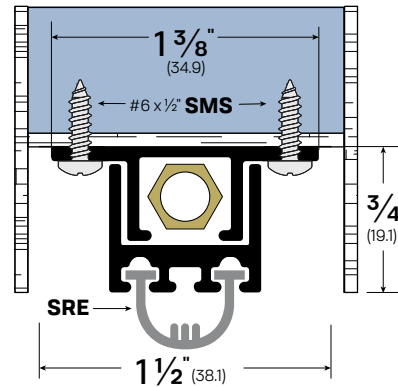

#72553

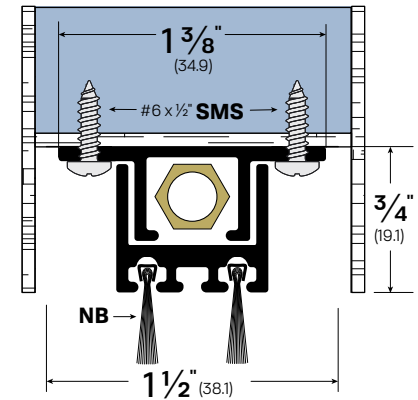

HINGE SIDE

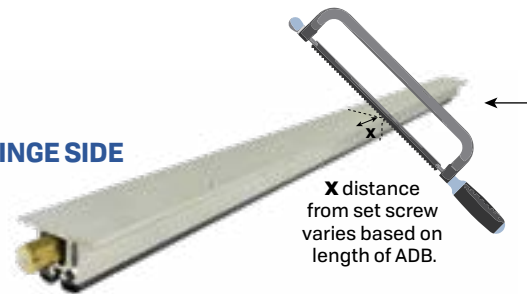

Trim from Lock Side

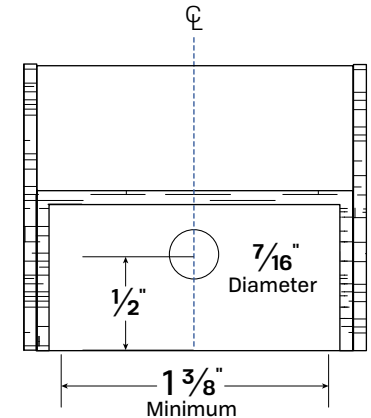
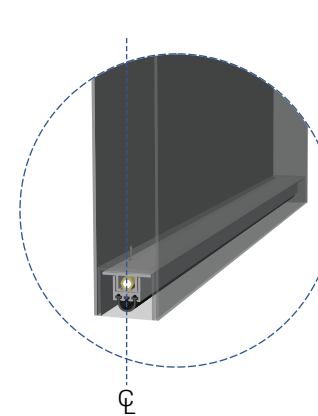

WARNING - Do not pull on the insert, rubber, or any components. Overextending the insert to a point lower than designed will result in binding of the unit and the inability of the insert to retract properly back into the housing. Any tampering will damage the mechanism, render the seal ineffective and void the warranty.